



IsatDock **LITE**



User Manual

Inmarsat IsatDock LITE Installation and User Manual

Product name: IsatDock LITE

Manual revision: 01

Part Number: USRMAN005901

Release date: October 2010



Remote Satellite Systems

1455 N. Dutton Ave., Ste. A, Santa Rosa, CA 95401
(707) 545-8199 www.remotesatellite.com

Information furnished by BEAM Communications Pty Ltd (BEAM) is believed to be accurate and reliable. However, no responsibility is assumed by BEAM for its use, or for any infringement of patents or other rights of third parties, which may result from its use. No license is granted by implication or otherwise under any patent or patent rights of BEAM. BEAM reserves the right to change specifications at any time without notice.

Copyright © 2010 BEAM Communications Pty Ltd. All rights reserved

About Beam Communications

Beam Communications, a wholly owned subsidiary of World Reach Limited (WRR), listed on the Australian Stock Exchange, is a world leader in design, manufacture and distribution of specialised communications equipment for the Inmarsat Satellite Network.

Beam's commitment to be at the forefront has continued to increase its share of the global satellite communications market. Its premium distribution network spans the world.

Recognized as a leading provider of satellite communication solutions, **Beam** specializes in Voice, Data, Tracking and customized solutions. **Beam** develops innovative products and services to meet market demands and niche applications.

Beam's leading edge products are deployed in a wide range of vertical markets including Maritime, Transport, Government, Defence, Mining, Construction, Forestry, Emergency Services, Relief Aid, Telemetry and Rural Telephony.

Supported by a dedicated team of professionals, **Beam** has developed solid relationships with its peers and network of distributors worldwide.



BEAM Communications Pty Ltd
8 Anzed Court, Mulgrave,
Victoria, 3170, AUSTRALIA



Remote Satellite Systems
1455 N. Dutton Ave., Ste. A, Santa Rosa, CA 95401
(707) 545-8199 www.remotesatellite.com

Tel: +61 3 8588 4500
Fax: +61 3 9560 9055

Conventions in this Manual

These notes will appear throughout this manual and should be taken into consideration.



Warning or Caution

This symbol and associated text indicate a warning note providing information to prevent damage to equipment or personal injury.



Note/Important/Tip Header

This symbol and associated text indicate a note providing general operating information.



Interference Header

All wireless phones may get interference, which could affect performance.



Record Header

Write details of your unit for easy reference when required. Ideal when troubleshooting.

Terminology

TERM	DESCRIPTION
IDMS	IsatDock Management System - MS Windows Install
SMS	Short Message Service
Mobile Originating	Describes a call initiated by the IsatDock
Mobile Terminating	Describes an incoming call being answered by the IsatDock
IsatPhone Pro	The Inmarsat IsatPhone Pro handset
®	The ® symbol, mark and logos are owned by the respective companies of which the symbol follows. Any use of such marks by Beam Communications is under license. Other trademarks and trade names are those of their respective owners.
RF	Radio Frequencies
SMA	SubMiniature version A co-axial RF connection
RJ9	4P4C connector for the privacy handset
GPS	Global Positioning System
GSPS	Inmarsat's Global Satellite Phone Service

Package Contents

Check that your IsatDock LITE package contains all of the following items:

- 1 x IsatDock LITE docking station
- 1 x DC Power Cable / Lead
- 1 x Universal Mounting Bracket (RAM)
- 3 x M4 Screw Set
- 1 x Fuse Kit
- 2 x Handset Locking Keys
- User Manual
- Quick Start Guide

IsatDock Management System (IDMS)

is available for download from:

[http://www.beamcommunications.com/
support/isatdock/IDMS](http://www.beamcommunications.com/support/isatdock/IDMS)

Optional Accessories

The following optional accessories are available for your IsatDock LITE

Active Antennas

- ISD710 Maritime Active Antenna
- ISD715 Transport Active Antenna (Magnetic)
- ISD720 Transport Active Antenna (Bolt)

Antenna Cable Kits for Active Antennas

- ISD932 6m cable kit (Active)
- ISD933 13m cable kit (Active)
- ISD934 18m cable kit (Active)
- ISD935 31m cable kit (Active)

Passive Antennas

- ISD700 Fixed Passive Antenna

Antenna Cable Kits for Passive Antennas

- ISD936 10m cable kit (Passive)
- ISD937 20m cable kit (Passive)

Additional Accessories

- ISD955 Privacy Handset
- ISD950 110-240v AC plug pack
- RST055 UPS Battery Pack

See your service provider for pricing and availability of these quality BEAM accessories.

Additional Information

For the latest in supporting software and documentation for IsatDock LITE please contact **www.beamcommunications.com/support**

Other Resources Available Online

- Advanced Configuration – in-built to IDMS
- Quick Start Guide & Manual
- Antenna Installation Guide
- IsatPhone Pro firmware upgrade if required

CONTENTS

Inmarsat IsatDock Drive Part Number	2	Guidelines for Electrical Connections	
About Beam Communications	3	Installation Procedure	14
Conventions in this Manual	4	Installing the IsatDock LITE Cradle	
Terminology		Connecting Power to the Dock	
Package Contents	5	IsatDock LITE Usage	19
Optional Accessories		Docking & undocking the IsatPhone Pro handset	
Additional Information		Operation of the IsatPhone Pro	
Other Resources Available Online		Placing Voice Calls	
Safety Information	7	Privacy Handset Use (Optional Accessory)	
Safety Inmarsat Transceiver IsatPhone Pro		Mute Mode	
IsatDock FCC Information		USB Driver Installation	
Electronic Devices		IsatDock LITE Front Panel	
Pacemakers		LED Status	
Other Medical Devices		Assuring Quality of Inmarsat Service	
Vehicles		Specification Summary	23
Posted Facilities		Electrical & Environmental Specifications - IsatDock LITE	
Aircraft		(1) Physical Dimensions - Lite Dock	
Vehicles Equipped with an Air Bag		(2) Physical Dimensions - Privacy Handset	
IsatDock LITE Key Features	11	Trouble Shooting	25
Equipment Overview	12	Beam Warranty Conditions	26
Installation Guidelines	13		
Routing Cables (for vehicle installations)			

Safety Information



IMPORTANT!

Please read the following information carefully before installing and using the IsatDock LITE.

Failing to follow instructions may compromise the safety of the product and may result in personal injury and/or equipment damage. Please consult your supplier if you have any further questions.

The IsatDock LITE is a low power docking station for the IsatPhone Pro handset. When ON, it will charge the IsatPhone Pro handset whilst docked in the IsatDock LITE.

Refer to the appropriate section of this IsatDock LITE Installation & User Manual for additional safety information.

- Store the system in a cool and dry area.
- Do not submerge the system in water.
- Do not place foreign metal objects or debris in the system. If debris enters into the system, please return to factory for service.



WARNING

DO NOT open equipment. There are no user-serviceable parts inside.

If a DC power supply is to be used, its output must comply with the Safety Extra Low Voltage (SELV) requirements of IEC60950.

All connectors must only be connected to equipment ports which comply with the Safety Extra Low Voltage (SELV) requirements of IEC60950.

POTENTIALLY EXPLOSIVE ATMOSPHERES

- Turn your phone OFF and DO NOT remove your battery or remove the IsatPhone Pro handset from the cradle when you are in any area with a potentially explosive atmosphere.
- Obey all signs and instructions.
- Sparks from your battery in such areas could cause an explosion or fire resulting in bodily injury or even death.

- Areas with a potentially explosive atmosphere are often but not always clearly marked. They include, but are not limited to:
 - » fuelling areas such as gasoline stations
 - » below deck on boats;
 - » fuel or chemical transfer or storage facilities;
 - » areas where fuel odors are present (for example, if a gas/propane leak occurs in a car or home);
 - » areas where the air contains chemicals or particles, such as grain, dust, or metal powders;
 - » any other area where you normally would be advised to turn off your vehicle engine.

Safety Inmarsat Transceiver IsatPhone Pro

Your handset is a low power radio transmitter and receiver. When it is ON, it receives and also sends out radio frequency (RF) signals.

(NOTE: Refer to Inmarsat IsatPhone Pro Manual for additional Information)

- The Inmarsat IsatPhone Pro handset has an in-built transceiver which is designed to be used with an external antenna. This antenna transmits RF energy. The Inmarsat antenna (fitted via an extension coaxial cable to the cradle) must be located more than > 0.55 meters from the human body (person) when in operation.
- International agencies have set standards and recommendations for the protection of public exposure to RF electromagnetic energy. These standards are based on extensive scientific review by scientists, engineers, and physicians from universities, government health agencies, and industry groups. They review the available body of research to develop ANSI standard. These ANSI standards are reviewed regularly for research development.
 - » International Commission on Non-Ionizing Radiation Protection (ICNIRP) 1996
 - » Verband Deutscher Elektrotechniker (VDE) DIN-0848
 - » United States Federal Commission, Radio Frequency Exposure Guidelines (1996)
 - » National Radiological Protection Board of the United Kingdom, GS 11, 1988
 - » American National Standards Institute (ANSI) IEEE. C95. 1-1992
- Do not operate your satellite telephone when a person is within 0.55 meters of the antenna. A person or object within 0.55 meters of the antenna could impair call quality and may cause the phone to operate at a higher power level than necessary and expose that person to RF energy in excess of that established by the FCC RF Exposure Guidelines.
- As a precaution, please maintain the maximum body distance possible from the antenna during call transmission.



WARNING

ROAD SAFETY COMES FIRST!

Do not use a hand-held cellular terminal, satellite phone or mobile when driving a vehicle, unless it is securely mounted in a holder for speaker phone operation. Before making a call with a handheld terminal, satellite phone or mobile, park the vehicle stationary. Please obey local road laws for hands-free speakerphone operation. Speakerphones (hands-free) must be installed by qualified personnel. Faulty installation or operation can constitute a safety hazard.



IMPORTANT

Cellular & Satellite terminals or mobiles operate using radio signals and communication networks. Because of this, the connection cannot be guaranteed at all times or under all conditions. Therefore, you should never rely solely upon any wireless device for essential communications, for example emergency calls.

IsatDock FCC Information

This equipment has been tested and found to comply with the limits for a Class B digital devices, pursuant to Part 15 of the FCC Rules. These limits are designed to provide reasonable protection against harmful interference in a residential installation. This equipment generates, uses, and can radiate radio frequency energy and, if not installed and used in accordance with the instruction manual, may cause harmful interference to radio communications. However, there is no guarantee that interference will not occur in a particular installation. If this equipment does cause harmful interference to radio or television reception, which can be determined by turning the equipment off and on, the user is encouraged to try to correct the interference by one of more of the following measures:

- Reorient or relocate the receiving antenna
- Increase the separation between the equipment and receiver
- Connect the equipment into an outlet on a circuit different from that to which the receiver is connected.
- Consult the dealer or an experienced radio/TV technician for help.

This device has been designed to operate with antennas ISD710 AT1595-82, ISD715/ISD720 AT1595-83 and having a maximum gain of 6dB i dB. Antennas having a gain grater than 6dBi dB are strictly prohibited for use with this device.

To reduce potential radio interference to other users, the antenna type and its gain should be so chosen that the equivalent isotropically radiated power (EIRP) is not more than that required for successful communication



WARNING

Changes or modifications not expressly approved by Beam Communications could void the user's authority to operate the equipment.

Electronic Devices

Most modern electronic equipment is shielded from RF signals. However, certain equipment may not be shielded against the RF signals from your wireless phone.

Pacemakers

The Health Industry Manufacturers Association recommends that a minimum separation of six inches (6") be maintained between a wireless phone's antenna and a pacemaker to avoid potential interference with the pacemaker. These recommendations are consistent with the independent research by and recommendations of Wireless Technology Research.

Persons with pacemakers:

- *Should ALWAYS keep the phone more than six inches from their pacemaker when phone is turned ON.*
- *Should turn the phone OFF immediately if you have any reason to suspect interference is taking place.*

Other Medical Devices

If you use any other personal medical device, consult the manufacturer of your device to determine if it is adequately shielded from external RF energy. Your physician may be able to assist you in obtaining this information.

Turn your phone OFF in health care facilities when any regulations posted in these areas instruct you to do so. Hospitals or health care facilities may be using equipment that could be sensitive to external RF energy.

Vehicles

RF signals may affect improperly installed or inadequately shielded electronic systems in motor vehicles. Check with the manufacturer or its representative regarding your vehicle. You should also consult the manufacturer of any equipment that has been added to your vehicle. Performance of electronically controlled brake and/or guidance systems can, under certain unique conditions, be subject to interference by mobile radio operation. Although the transceiver meets all requirements regarding RF emissions, you should mount the transceiver as far as possible from the guidance system and/or braking modulator box (usually located in the trunk) to minimize any interference.

Posted Facilities

Turn your phone OFF in any facility where posted notices require such as hospitals and on-board aircraft.

Aircraft

Airline regulations prohibit using your phone while in the air. Consult the local Aviation Authority for guidelines on use of the equipment on board an aircraft.

Vehicles Equipped with an Air Bag

An air bag inflates with great force. Do NOT place objects, including both installed and portable wireless equipment, in the area over the air bag or in the air bag deployment area. If in-vehicle wireless equipment is improperly installed and the air bag inflates, serious injury could result.

IsatDock LITE Key Features

The IsatDock LITE enables the IsatPhone Pro to be always on and ready to receive incoming calls, that can be answered via a Bluetooth accessory or the optional privacy handset. The IsatPhone Pro handset, fits securely in the Dock which is also key lockable, other features include phone charging, USB data* port, inbuilt ringer and allows antenna and power to be permanently connected to the Dock ready for use.

IsatDock LITE Design

- Slimline design
- High quality ABS plastic
- Single action insertion mechanism
- Insertion guides
- Single button release
- Key lockable
- RAM universal mounting bracket
- Integrated cable assemblies
- Robust GSPS/GPS antenna connection
- Accessible control buttons

* Data services available Q1 2011

Power

- 10-32V DC Input
- 110-240V AC plug pack, optional

Buttons on Dock

- In-call mute
- Ring tone selection
- In-call volume up/down

Accessing Voice Services

- Bluetooth Accessory via handset
- Privacy Handset (Optional Accessory)
- IsatPhone Pro Speaker (limited Volume)

Other Key Features

- Keeps phone always charged
- Adjustable inbuilt ringer
- Status LED with adjustable brightness
- Includes universal RAM bracket

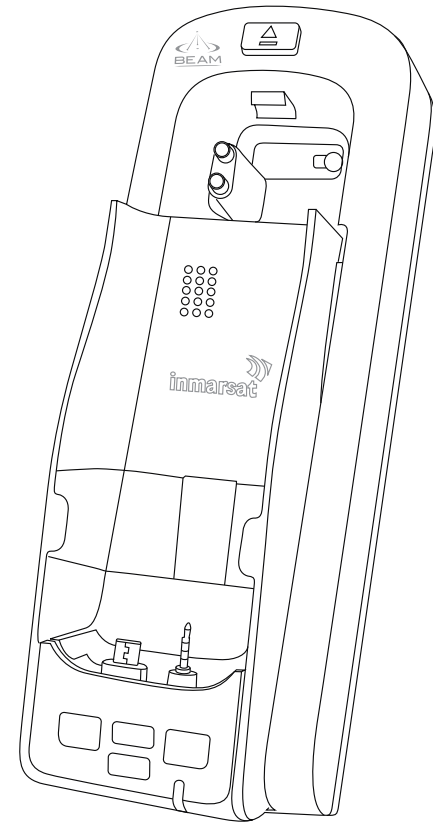

Equipment Overview

IsatDock LITE

1. IsatDock LITE Unit
2. Key lock
3. IsatPhone Pro Eject Button
4. IsatPhone Pro (not included)
5. IsatPhone Pro Docking Tray
6. Function Buttons
7. Status Indication Light
8. Power Cable Loom
 - a. Power Supply
 - b. Satellite TNC-Female Connector
 - c. GPS SMA-Female Connector
9. RAM Mounting
10. RJ9 Privacy Handset Connection
11. Micro USB Data Connection*

* Data services available Q1 2011.
Firmware upgrade will be required.

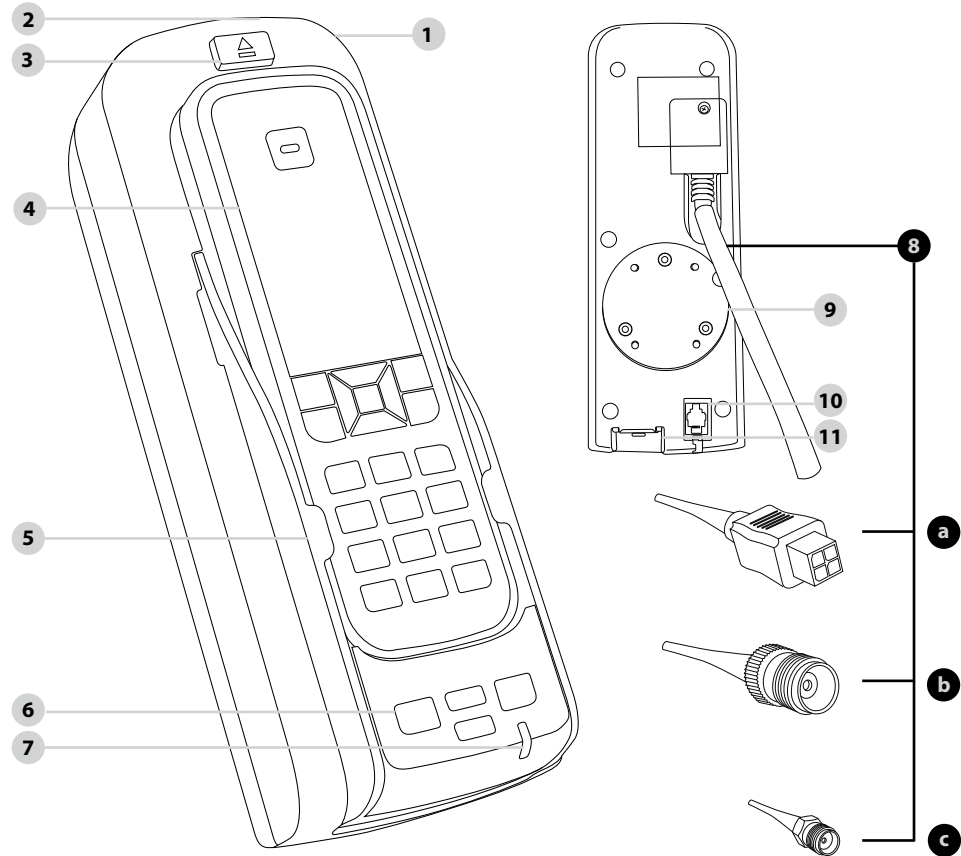

Installation Guidelines

This guide outlines the process for installing the IsatDock LITE in conjunction with an Inmarsat IsatPhone Pro handset.

This kit must not be used with any other device other than the Inmarsat IsatPhone Pro handset.

- Only qualified personnel should install communication equipment. If necessary, contact the vehicle manufacturer for air bag information specific to the vehicle.
- Ensure that the units are protected from dirt and moisture.
- Select an area to mount components that do not interfere with driver or passengers seating or leg space.
- Ensure that each mounting surface is strong enough to support the component being mounted to prevent the component from loosening over time.
- Mount all components securely to prevent shifting that could cause injury or could interfere with safe vehicle operation. Always use the supplied mounting hardware.
- Leave space around the units to allow cooling and ensure there are adequate clearance for cables.
- Ensure the units can be easily removed.

Routing Cables (for vehicle installations)

- Route cables so they are protected from pinching, sharp edges, and crushing.



WARNING

Air bags inflate with great force. DO NOT place objects, including communication equipment, in the area over the air bag or in the air bag deployment area. If the communication equipment is improperly installed and the air bag inflates, serious injury could result.

-
- *Where possible, avoid routing cables above the catalytic converter.*
 - *Use grommets wherever a cable must pass through a hole in a metal panel*
 - *In a vehicle equipped with electronically controlled anti-skid brakes, route all cables on the opposite side of the vehicle from the braking modulator box to minimize possible interference from the phone.*
 - *Keep all in-line connectors accessible.*
 - *The suggested path for routing cables in vehicles without wiring troughs is alongside the drive shaft hump, under the carpet.*

Guidelines for Electrical Connections

The system is designed to operate in negative ground 10 to 32 Volt DC electrical systems only. If using the DC cable lead:

- The best power connection point for the positive primary power leads is the positive terminal of the vehicle battery. Often, direct connection to the battery is inconvenient, and you may find it easier to connect the positive leads to the starter solenoid. Always select a point as close as possible to the battery.
- Connect the negative primary power leads to a good ground point on the vehicle chassis or at the battery. If you must attach the negative primary power lead(s) directly to the negative pole of the battery, you may optionally insert a 10-amp fuse (not included) into the ground (0V) line. Failure to insert a fuse can cause equipment to overheat if a wiring fault exists.
- Many parts of a vehicle can produce electrical noise that interferes with the electrical radio system operation. The ignition system is the most common source of electrical noise interference. Before you begin installation, ensure that the ignition wiring and connections to the vehicle battery are in good working condition.

- Verify that low resistance connections are present between the battery negative terminal, the vehicle chassis, and the engine block. All wire connections should be clean and tight.



WARNING

Do not connect the IsatDock LITE interface power cable to power the unit until the full installation is completed.

Installation Procedure

Installing the IsatDock LITE Cradle

Install the components in the following order. More detailed instructions can be found in the sections following.

1. Mount the IsatDock LITE cradle
2. Install the external Inmarsat antenna
3. Connect the privacy handset (ordered as extra option)
4. Connect the DC power cable

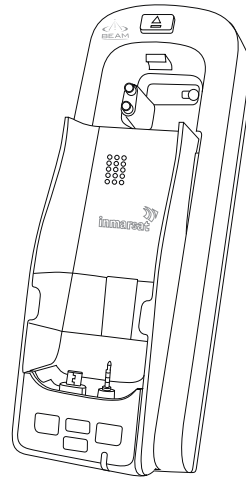

When selecting a location for the IsatDock LITE cradle, consider these guidelines:

- Ensure that each mounting surface is strong enough to support the cradle.
- Allow enough room so that you can easily insert the IsatPhone Pro handset in and out from the cradle.
- Ensure that the IsatDock LITE is within cable distance of power and antenna connections
- Position the handset and cables so that it does not interfere with vehicle operation or with driver or passenger seating or leg space.
- Ensure sufficient room is allowed for the antenna and interface cables to be routed from the rear of the IsatDock LITE cradle.

1) Mounting the IsatDock LITE Cradle

The IsatDock LITE is supplied with a universal RAM® mount bracket that enables mounting to any flat surface (vertical or horizontal) within a vehicle, attached on a wall or on a table as required.

1. Attach one pivot base to the rear of the IsatDock LITE using the M4 screws supplied.
2. Secure the second pivot base to the location you have selected for mounting the IsatDock LITE.
3. Use the interconnecting step of the RAM® mount to secure the IsatDock LITE to the pivot base and tighten into the desired location firmly using the wing nut on the stem.

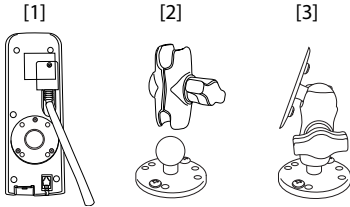

2) Install the external Inmarsat Antenna

The antenna connections exit from the rear of the IsatDock LITE cradle, via the antenna loom. There are two RF connections required, the Satellite TNC – Female Connector and GPS SMA-Female connector.

1. Refer to the antennas installation guide for antenna mounting and location requirements
2. Connect the antenna cable labelled “Inmarsat” to the IsatDock’s TNC connector
3. Connect the antenna cable labelled “GPS” to the IsatDock’s SMA connector
4. Connect the antenna cable labelled “Inmarsat” to the antenna via the SMA connector.
5. Connect the antenna cable labelled “GPS” to the antenna via the SMA connector

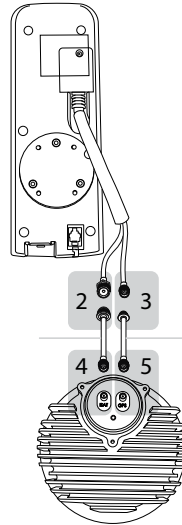

WARNING

DO NOT pull with force on the cables from the rear of the IsatDock LITE. Please install strain relief clamping for the antenna cables where required. Correct installation of the antenna system is a vital part of the IsatDock LITE system, to ensure reliable functionality, and drop-free calls.

WARNING

Changes or modifications not expressly approved by Beam Communications could void the user’s authority to operate the equipment.

WARNING

To satisfy FCC RF exposure requirements for mobile transmitting devices, a separation distance of 55 cm or more should be maintained between the antenna of this device and persons during device operation. To ensure compliance, operations at closer than this distance is not recommended.

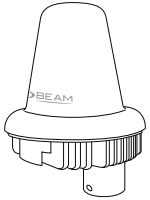

Marine Active
Antenna with Pole
Bracket

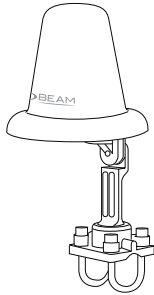

Passive Antenna
with Bracket



Transport
Active Antenna



Magnetic
Mount



Bolt Mount



NOTE

The antenna should only be connected and disconnected when the IsatDock LITE is not powered. Connecting the antenna after power-up can result in prolonged acquisition time.



NOTE

Refer to the section "Antenna Installation" for more information on antenna placement and installation.

3) Connect the Privacy Handset (Optional – Extra Order)

The IsatDock LITE provides a RJ9 audio socket on the bottom of the docking unit, for connection to the Beam privacy handset. This provides a local handset function, conveniently mounted next to the IsatDock LITE cradle.

1. The Privacy Handset Kit (purchased/ordered separately) contains a mounting bracket, space plate, and fasteners.

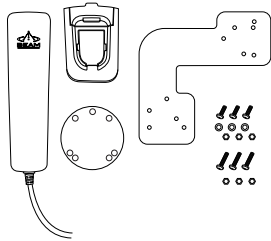

2. Mount the handset cup to the mounting plate, it can be installed to the left or right side of the dock by simply rotating the bracket.

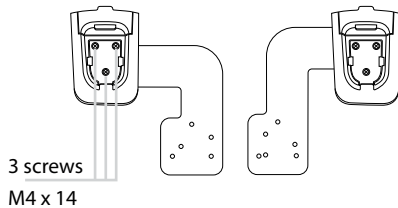

Left and right configuration

3. Mount the spacer plate and the mounting bracket to the rear of the IsatDock LITE, by using the longer screws provided with the kit. The original RAM® arm-bracket plate is also re-installed behind these plates. Install in the following order:

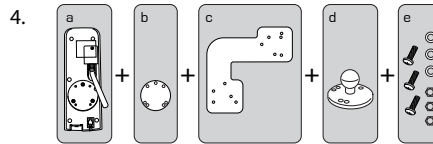

[a] Rear of IsatDock LITE [b] Spacer
[c] Mounting plate [d] RAM base
[e] 3 x Mounting screws

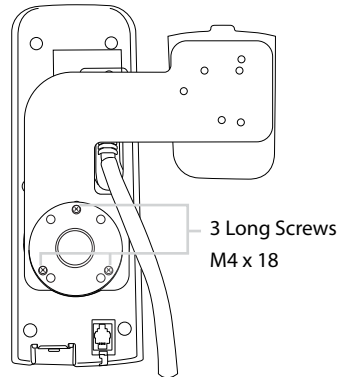

5. Plug the Privacy Handset RJ9 connector into the bottom of the docking unit, as per image below.

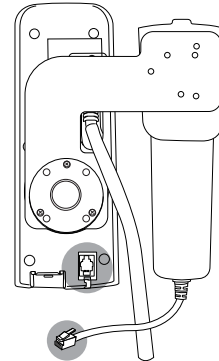
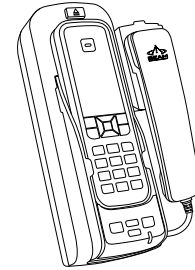

Privacy Handset mode is enabled when the handset is removed from the cup. Please ensure to re-dock the Privacy Handset when not in use.

4) Connecting the DC Power Cable

The Dock can be powered from the supplied 10-32V DC power cable/lead.

The DC power cable has three wires, RED, BLACK and YELLOW.

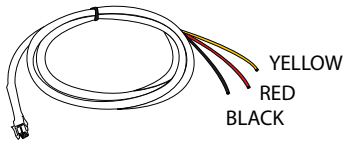

The RED and BLACK wires are used for the power connection while the YELLOW wire can be connected to a vehicle's accessories, ignition or other similar circuits to control the ON/OFF status of the IsatDock LITE in synchronization with a vehicles operation.

By default, the IsatDock LITE will stay on for 20 minutes after this input is switched off. If a call is in progress while this occurs, the IsatDock

LITE will stay on for 20 minutes after the call is terminated. Please follow the steps below to connect the DC power cable to the vehicle battery power and the IsatDock LITE.

1. Connect the 4-way Microfit connector on the DC power cable to the 4-way power connector on the rear cable loom of the IsatDock LITE.
2. Route the wire end of the DC power cable to the connection point. DO NOT apply power until the following steps are completed.
3. Connect the BLACK wire to the negative terminal of the battery (10A fuse recommended) or the vehicle chassis (if negatively grounded chassis).
4. Connect the RED wire to the positive terminal of the battery. It is recommended to add a 5A fuse between them (supplied).

5. Connect the YELLOW wire to the vehicle accessory power. If the accessory power is unavailable, this may be connected to a vehicle ignition voltage. It is recommended to add a 1A fuse between them. The accessory wire enables the IsatDock LITE to turn on and off as the vehicle key is enabled or disabled. If this function is not required, the YELLOW wire MUST be connected to the RED wire.

Wiring for a Marine Application

When installed in a marine application using the DC power cable, the YELLOW wire can be wired to a suitable panel switch which will allow the IsatDock LITE to be turned off when not in use.

Optional ISD950 AC Plug Pack Installation

For installation with the optional ISD950 110-240 AC plug pack connect the 4-way Microfit connector from the plug pack to the 4-way power connector on the rear cable loom of the IsatDock LITE. In this configuration the ignition/accessory status is always ON.

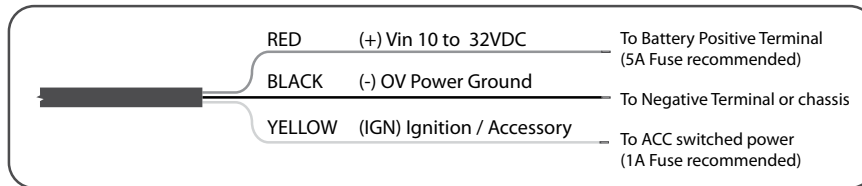

IsatDock LITE Usage

Docking & undocking the IsatPhone Pro handset

To place the IsatPhone Pro into the docking unit, both the 'covers' on the external antenna connectors and the USB/Audio connectors need to be opened.

1. The antenna 'cover' must be placed at 90° degrees to the antenna connector cavity and run parallel to the top edge of the phone.
2. The 'cover' in the base of the phone should be at a 90° degrees fully opened position.

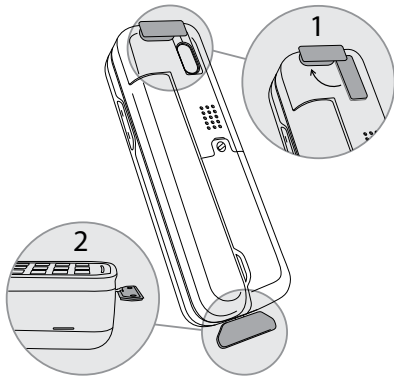

3. To dock the handset, align the IsatPhone Pro with the phone tray and slide the handset down until it seats flush to the bottom of the tray. Swing the phone down into the

cradle by applying pressure to the top of the handset. An audible 'click' is heard when the phone is in the docked position.

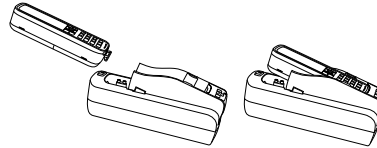

4. To remove the handset from the cradle, press the EJECT button at the top of the docking station. The dock will swing out and the handset can be removed.

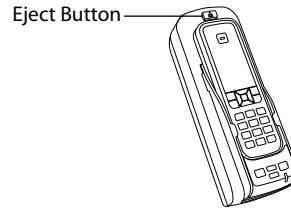

Operation of the IsatPhone Pro Prepare the Inmarsat IsatPhone Pro

Ensure that the IsatPhone Pro Handset has the latest compatible firmware installed. For more information visit:

www.beamcommunications.com/support/isatdock

Starting Up

1. Retract the antenna on the IsatPhone Pro handset.
2. Place the IsatPhone Pro as per instructions "Docking & Undocking" on page 20.
3. Turn vehicle ignition on. The IsatPhone Pro will automatically power up followed by a rising beep, once the docking station has successfully synchronized with the IsatPhone Pro.
4. Wait for the IsatPhone Pro handset to register on the Inmarsat network. The STATUS LED on the docking station will turn green when a successful registration has taken place.
5. You are now ready to make and receive calls.



NOTE:

If the IsatPhone Pro is removed from the dock during a call, the call will drop out during this transition.

Charging the IsatPhone Pro handset

The IsatDock LITE provides charging power to the IsatPhone Pro handset via its USB connector.

The IsatPhone Pro battery is a lithium-ion cell which has a safety temperature range whilst charging. This range is from 0 to 45 degrees Celsius (32 to 113 degrees Fahrenheit).

Due to the increased heating effects on the IsatPhone Pro handset whilst it is docked and being charged, it is ideal for the ambient temperature to be approximately 15 degrees below the 45°C upper limit for the handset to charge the battery whilst docked. If the battery temperature exceeds this limit, then the IsatPhone Pro may cease charging until the temperature is reduced.

Placing Voice Calls

Bluetooth® calls via IsatPhone Pro

The IsatDock LITE allows for Bluetooth audio calls to be placed via the IsatPhone Pro handset while docked. Consult the IsatPhone Pro manual for further information on pairing and Bluetooth discovery setup.

Privacy Handset Use (Optional Accessory)

Privacy handset Phone Call - Mobile

Originating

1. Remove the privacy handset from its cup
2. Dial the phone number (using the full country code) on the IsatPhone Pro keypad whilst docked. Press the GREEN button to start the connection.
3. A message is displayed on the IsatPhone Pro to indicate a call is in progress.
4. Once the call is connected, the STATUS LED will flash to indicate a call is in progress.
5. Press the RED key on the IsatPhone Pro handset or return the privacy handset to its cup to terminate the call.

Privacy Handset Phone Call - Mobile Terminating

1. Answer the incoming call by un-cupping the privacy handset from its cup.
2. Press the RED key on the IsatPhone Pro handset or return the privacy handset to its cup to terminate the call.

Mute Mode

Mute functionality

The mute function of the IsatDock LITE allows the user to mute the uplink microphone audio on the privacy handset.

1. During a call, Press the Mute button on the face of the IsatDock LITE, a RED LED will illuminate the Mute button to confirm that the IsatDock LITE is muted.
2. To exit the mute mode, press the mute button once.

USB Driver Installation





The IsatDock LITE USB data port requires an interface driver to be installed on the user's computer prior to undertaking data communication. This driver supports the following operating systems:

Windows XP (SP3 or above) & Windows Vista

You can download the Windows driver for the IsatDock from

<http://www.beamcommunications.com/support/isatdock>

IsatDock LITE Front Panel

LOCATION	BUTTON MODE	ACTION	LED/SOUND
	Ringer Press (1 second)	Out of Call: Toggle through the available ring tones	Hear ring tone change.
	Mute Press ON/OFF	In a Call: Mute the microphone (uplink) on the privacy handset (optional accessory) if connected to cradle.	LED turns RED - Muted LED turns OFF - Not muted
	Up	In a Call Increase volume on the privacy handset (optional accessory) if connected to cradle.	Audio will sound louder in privacy handset with each press.
	Down	In a Call: Decrease volume on the privacy handset (optional accessory) if connected to cradle.	Audio will sound quieter in privacy handset with each press.
	Brightness dual button simultaneous press (1 second)	Out of Call: Enter LED brightness change mode. Press UP and DOWN arrows to vary intensity. Mode will automatically exit after 5 seconds after the last button press.	All LED's will change to WHITE and a single beep will sound when entering brightness change mode. A short double beep will sound when exiting change mode.

IsatDock LITE Buttons/LED Status

MUTE	GREEN	RED
ILLUMINATED	N/A	Uplink audio muted
STATUS	GREEN	RED
ILLUMINATED	Handset registered and able to make a call	Handset not registered / no signal and cannot make a call
FLASHING	Call in Progress	N/A
ALTERNATING	Error detected in communicating with IsatPhone Pro handset	

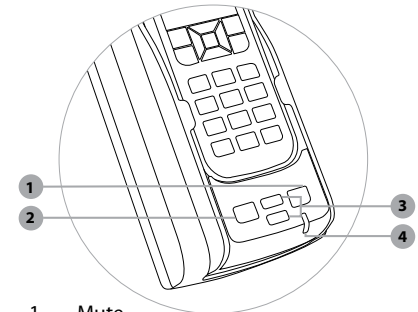

1. Mute
2. Ringer
3. Up & Down
4. LED STATUS

Assuring Quality of Inmarsat Service

Inmarsat is committed to providing subscribers around the world with consistent, reliable, quality voice and data access all day, every day. The Inmarsat satellite system is monitored for call performance from numerous locations 24 hours a day, 7 days a week in order to achieve this. There are conditions that can compromise the quality of the service you may receive. These include:

- Obstructions
- Cabling
- RF Interference

Obstructions

Nearby tall buildings or similar structures, heavily leafed trees and mountains can all degrade performance as they block the signal between the antenna and the satellites.

Inmarsat performance is immune from natural environments such as clouds, fog, rain, snow, wind and smoke.

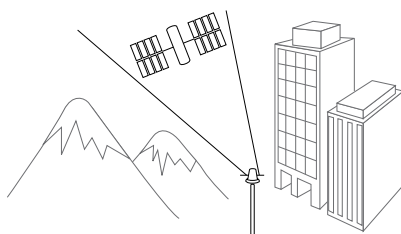

Cabling

Using an externally mounted antenna provides an ideal solution for many applications. It is very important that both the antenna cabling and antenna are Beam approved products. Always ensure all RF connectors are screwed together firmly and ensure there are no sharp bends in the cabling between the docking station and the antenna.

RF Interference

All wireless devices, including satellite telephones, are susceptible to RF (radio frequency) interference from other electronic devices. This problem is more evident when numerous antennas and broadcasting devices are located within close proximity to each other.

Symptoms of RF Interference

Symptoms of RF interference often resemble those that arise when an antenna is being operated with an obstructed view of the sky. Some of these symptoms include; erratic or no signal strength indication dropped calls or warbled or otherwise distorted voice. These symptoms may be intermittent or persistent, depending largely on the interference source, its distance, strength and frequency relative to the Inmarsat unit.

Mitigation of RF Interference

Inmarsat Service degradation due to RF interference can be significantly improved by:

- Increasing the distance and moving the Inmarsat antenna off axis from the source of the interference, and
- Using an external band pass filter and an external antenna.



WARNING

Failure to use Beam approved antenna cables will result in degraded performance and may damage the IsatPhone Pro

Specification Summary

Electrical & Environmental Specifications - IsatDock LITE

Average Power Consumption Current @ 12V	Average	Watts
Power w/o IsatPhone Pro	130mA	1.6W
Standby + Charging	360mA	4.3W
Transmit + Charging	875mA	10.5W
Sleep Mode	5mA	60mW
Peak Current	3.5A	42W
Physical Specifications		
Dimensions	230 x 84 x 80 (mm)	9.1 x 3.3 x 3.2 (inches)
Weight - dock	565g	1.24lbs
Total Kit Weight	1.35kg	2.98lbs
Environment Specifications		
Operating Range	-30°C to +70°C	-22°F to +158°F
Storage	-35°C to +85°C	-31°F to +185°F
Battery Charging Temp*	0°C to +45°C	+32°F to 113°F
Humidity	<= 75% RH	
Connectors / Interfaces		
Inmarsat Antenna	TNC-Female	
GPS Antenna	SMA-Female	
10-32V DC	4-way microFit (AC/DC adaptor, or DC lead)	

Privacy Handset Port	RJ9 connector
Certifications	
Inmarsat	
FCC	
CE Compliance	
Electrical Safety	
RoHS	
Industry Canada	
C-Tick	
EMC Compliance	
Accessories	
LTO - LeoTRAK-Online	
ISD715 - Transport Active Antenna (Magnetic)	
ISD720 - Transport Active Antenna (Bolt)	
ISD932 - 6m SMA/TNC cable kit	
ISD933 - 13m SMA/TNC cable kit	
ISD934 - 18m SMA/TNC cable kit	
ISD935 - 31m cable kit	
ISD955 - Privacy Handset	
RST410 - "Alert Pendant" kit	
RST055 - UPS Battery Pack	
Kit Contents	
IsatDock LITE	
10-32V DC power cable	
Universal mounting bracket (RAM)	
Handset locking key	
User manual	
Quick start guide	



NOTE:

Specifications are subject to change without notice.

** It is ideal for the ambient temperature to be approximately 18 degrees below the 45°C upper limit for the handset to charge the battery whilst docked.*

(1) Physical Dimensions - LITE Dock

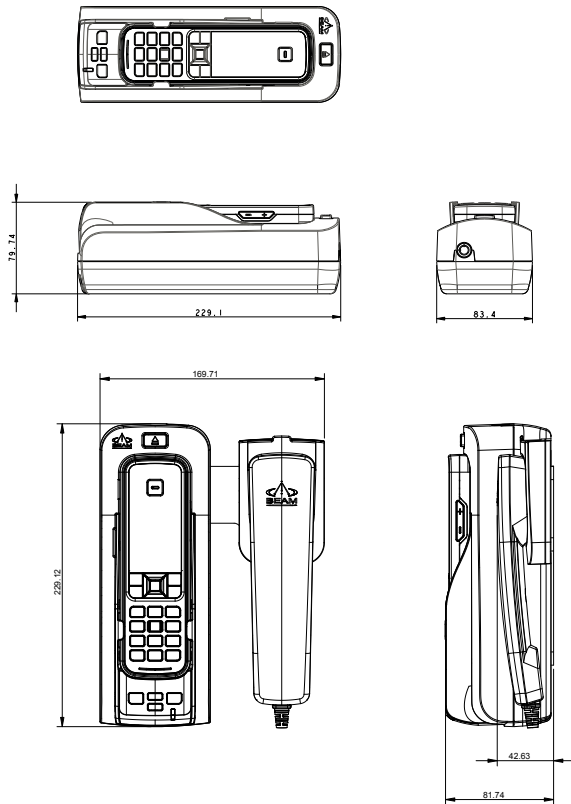

(2) Physical Dimensions - Privacy Handset

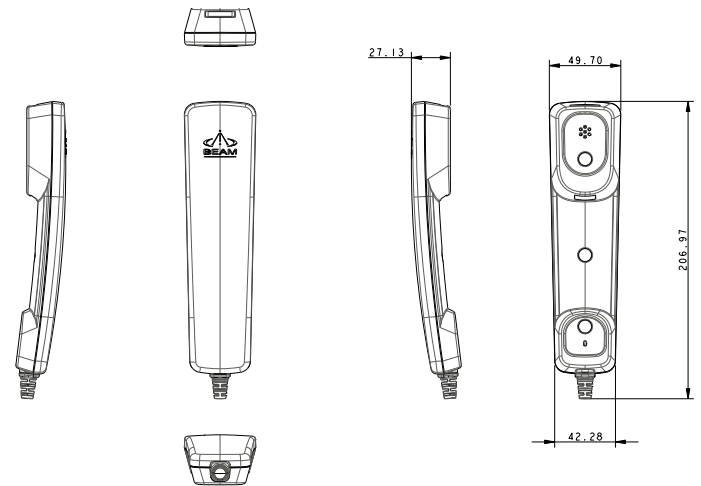

Trouble Shooting

This chapter provides information to help you troubleshoot problems you may encounter while running the IsatDock.

Q1	How do I know if my IsatPhone Pro is registered on the Inmarsat network?
A	<i>The STATUS LED of the docking station will change to GREEN when the handset is registered and able to make calls on the network. The IsatPhone Pro will also indicate "Inmarsat" in the top left corner of the screen display.</i>
Q2	The handset and docking station turn's OFF every 20minutes?
A	<i>Ensure the Ignition/Accessories wire is connected to power. If this is not connected, or connected to ground the docking station will go into sleep mode after 20 minutes by default.</i>
Q3	No power on IsatDock.
A	<i>Check power is connected to the interface unit. If applicable, check the vehicle ignition is in ACC or IGN or ON position. Ensure the Connector cable to the IsatDock is firmly fitted. Check all the connection cables to and from the IsatDock.</i>

Q4	The signal bars are low or fluctuating and call quality is poor.
A	<i>Ensure all antenna connectors are tight. The antenna is operating in a location that it can see the satellite and there are no obstructions. Beam certified antenna cabling is being used and there are no sharp bends or cuts in the cable. If using a fixed passive antenna, ensure it is orientated correctly and pointing at the satellite.</i>
Q5	I am looking for the latest manuals and support information on the docking station ?
A	<i>Visit: http://www.beamcommunications.com/isatdock</i>
Q6	Dropped calls
A	<i>Due to a satellite network when you are in motion the satellite signal may become obstructed (such as buildings, bridges, tunnels, larger vehicles). Check the antenna connection. Ensure the antenna cable has not been damaged. Ensure that only approved antenna cable has been used. Refer to Antenna Install Guide on Beam website support.</i>

Q7	Party B cannot hear your voice.
A	<i>Privacy Handset must be docked in its cup when not in use. Check that MUTE is not ON (indicated by turning RED) Check the signal strength on the handset. Ensure the Headset connector at the base of the IsatPhone Pro is not obstructed and there is no dust or foreign objects in the connector socket.</i>
Q8	The docking station appears to be turning ON/OFF and the handset is not registering.
A	<i>Ensure the power supply can provide at least 3.5A at 12volts. If power is being supplied from a battery, ensure the connections are tight and the contacts are clean.</i>

Beam Warranty Conditions

BEAM Communications gives this express warranty (along with extended warranty endorsements, where applicable) in lieu of all other warranties, express or implied, including (without limitation), warranties of merchantability and fitness for a particular purpose. This constitutes our sole warranty and obligation with regard to our products as well as the Customer's sole remedy.

BEAM Communications expressly disclaims all liability and responsibility for any special, indirect or consequential damages or any further loss of any kind whatsoever resulting from the use of our product(s).

The Customer's sole and exclusive remedy and the limit of BEAM liability for any loss whatsoever, shall not exceed the purchase price paid by the Customer for the product to which a claim is made.

All products manufactured by BEAM Communications are warranted to be free from defects in material and workmanship in accordance with and subject to the following terms and conditions:

1. This warranty is limited to the original Customer only. It cannot be transferred or assigned to third parties unless the intent to transfer to a third party is expressly indicated in a purchase order and/or warranty-processing arrangements have been agreed upon in writing by BEAM.
2. BEAM Communications does not warrant any installation, maintenance or service of the Products not performed by BEAM, nor does it warrant the use of Products with unapproved ancillary products.
3. BEAM Communications will correct any defects in material or workmanship of products manufactured by BEAM which appear within (12) months and (24) months replacement warranty for IsatDock cradles ONLY, from the date of shipment by BEAM Communications to the Customer. BEAM Communications will repair or replace, at our option, any defective product, provided that our analysis and/or inspection discloses that such defects developed under normal and proper use.
4. This warranty does not extend to goods subjected to liquid or particulate ingress, extreme humidity, misuse, neglect, accident or improper installation, or to maintenance or repair of products that have been altered or repaired by anyone except BEAM Communications unless otherwise stated in writing.
5. The warranty is a return-to-base warranty and freight is paid by the sender.
6. A charge of USD \$150 including return freight will be made for testing returned product which is not defective or is found to be defective as the result of improper use, maintenance or neglect.
7. BEAM Communications will not accept responsibility for any invoiced goods or services that are not covered by a BEAM Communications written purchase order. Under no circumstances does BEAM Communications agree to pay for labour or other related expenses associated with the troubleshooting and/or repair of our product without prior specific written authorization.
8. Information in our descriptive literature is based on product specifications that are current at the time of publication. Product specifications, designs and descriptive literature are subject to change as improvements are introduced. Although we announce changes as they occur, we cannot guarantee notification to every Customer. BEAM Communications warrants delivered product to conform to the most current specifications, designs and descriptive literature.
9. This warranty policy may be expanded or limited, for particular categories of products or Customers, by information sheets published as deemed appropriate by BEAM Communications. The warranty for third party Products is that of the third party and not BEAM warranty.

BEAM Communications Pty Ltd
8 Anzed Court, Mulgrave
Victoria, 3170, AUSTRALIA

Tel: +61 3 8588 4500 Fax: +61 3 9560 9055

Web: www.beamcommunications.com
Info: info@beamcommunications.com
Support: support@beamcommunications.com

